

INSTRUCTION MANUAL

CHEMTROL™ 250 ORP/pH DIGITAL CONTROLLER

For CHEMTROL™ 240 pH Controller: Disregard ORP Instructions
For CHEMTROL™ 230 ORP Controller: Disregard pH Instructions

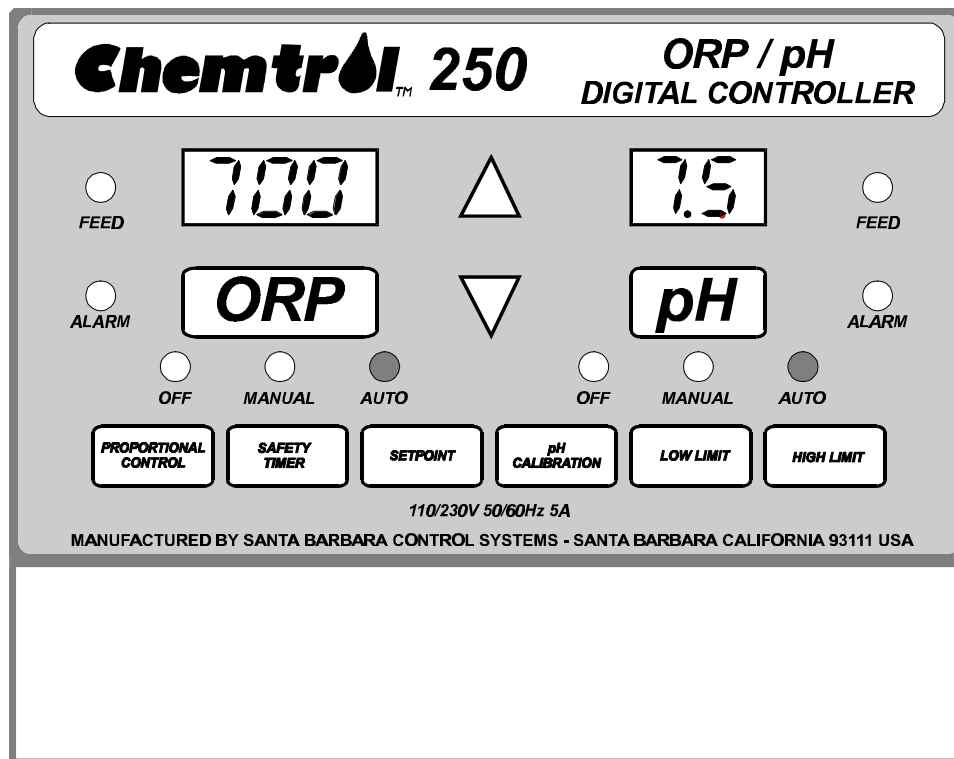

TECHNICAL SUPPORT

TOLL FREE	800-621-2279
PHONE	805-683-8833
FAX	805-683-1893
EMAIL	ch250@sbcontrol.com

Chemtrol™

A Division of SANTA BARBARA CONTROL SYSTEMS
5375 Overpass Road, Santa Barbara CA 93111

IMPORTANT SAFETY INSTRUCTIONS

Mandated by ITS Testing Laboratories, Inc

1. **READ AND FOLLOW ALL INSTRUCTIONS**
2. **WARNING** - To reduce the risk of injury, do not permit children to use this product unless they are closely supervised at all times.
3. **WARNING** - Risk of Electric Shock. Connect only to a grounding type receptacle protected by a ground-fault circuit interrupter (GFCI). Contact a qualified electrician if you cannot verify that the receptacle is protected by a GFCI. (Only required for cord-connected units.)
4. Do not bury cord. Locate cord to minimize abuse from lawn mowers, hedge trimmers, and other equipment. (Only required for cord-connected units.)
5. **WARNING** - To reduce the risk of electric shock, replace damaged cord immediately. (Only required for cord-connected units.)
6. **WARNING** - To reduce the risk of electric shock, do not use extension cord to connect unit to electric supply; provide a properly located outlet. (Only required for cord-connected units.)
7. **SAVE THESE INSTRUCTIONS.**

WARRANTY

This CHEMTROL™ 250 ORP/pH Electronic Controller S/N _____ is warranted by SANTA BARBARA CONTROL SYSTEMS (SBCS) to be free from defects in manufacturing and workmanship for a period of FIVE (5) YEARS from the date of purchase for the electronic module and ONE (1) YEAR for all other components. SBCS will repair or replace, at its option, any defective part during the warranty period. Labor, shipping or incidental expenses are specifically excluded from this warranty. For warranty coverage, defective parts should be returned immediately to your CHEMTROL™ Dealer or to our factory postpaid with a copy of your purchase receipt and a detailed description of the malfunction.

TABLE OF CONTENTS

IMPORTANT SAFETY INSTRUCTIONS	2	REMOTE ALARM	5
WARRANTY	2	PROPORTIONAL FEED	6
TABLE OF CONTENTS	2	CONTROLLER RESET	6
INTRODUCTION	3	STARTUP	6
INSTALLATION	3	DEFAULT PARAMETERS	6
LOCATION	3	WATER CHEMISTRY	6
ELECTRICAL WIRING	3	AUTOMATIC CONTROL	6
SENSOR INSTALLATION	3	MAINTENANCE	7
BYPASS LINE	4	GENERAL MAINTENANCE	7
FLOW SWITCH	4	SENSOR TESTING	7
CHEMICAL FEED PUMPS	4	SENSOR CLEANING	7
EROSION FEEDER	4	SENSOR REPLACEMENT	7
OPERATION	4	SENSOR STORAGE	7
ACID/BASE JUMPER	4	WINTERIZATION	7
FEED MODE	5	PARTS LIST	7
ORP CONTROL SETPOINT	5	OPTIONS	7
pH CALIBRATION	5	SPECIFICATIONS	7
pH CONTROL SETPOINT	5	TROUBLESHOOTING	8
OVERFEED SAFETY TIMERS	5	TERMINAL BLOCK WIRING	8
OUT-OF-RANGE ALARMS	5		
SANITIZER/pH INTERLOCK	5		

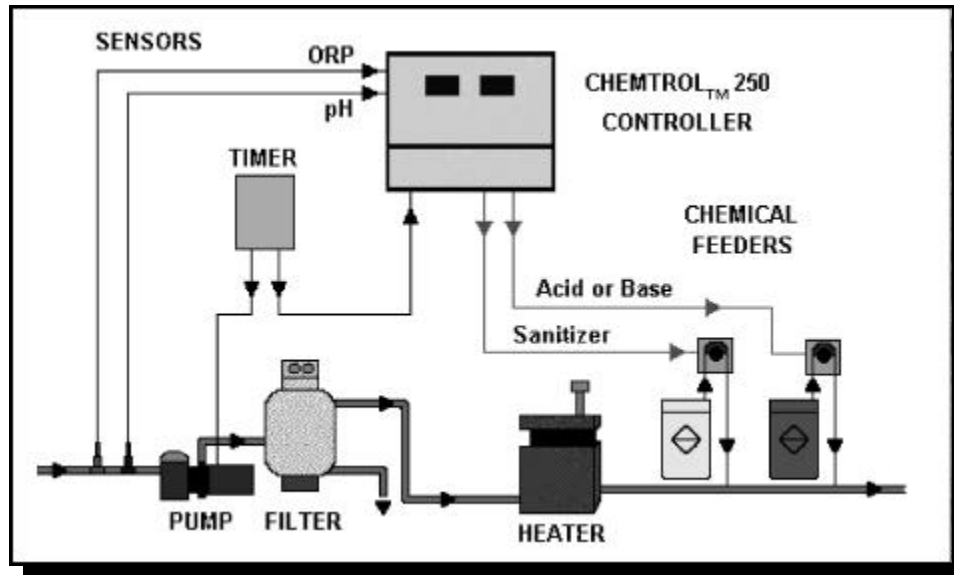

Figure 1 - Schematic of Installation with Sensors on Main Line

INTRODUCTION

The CHEMTROL™ 250 ORP/pH Controller is a microprocessor-based digital controller designed for controlling both ORP (Oxidation-Reduction Potential or Redox) and pH in swimming pools, spas, cooling towers and industrial applications.

Inputs include an ORP sensor to monitor sanitizer activity, a pH sensor and a safety flow switch (optional). The outputs are two relays for sanitizer and pH feed - acid or base - plus a relay for an optional remote alarm or telephone dialer.

INSTALLATION

LOCATION

Mount the cabinet as shown in Figure 1 in a well-ventilated area, away from chemical fumes and protected from direct sunlight. For electrical safety, the controller should be located more than 10 ft (3 m) from the water edge.

The sensors come with standard 10-foot (3-m) cables. If this is not sufficient to reach the recirculation line or the bypass line, order 25 or 50-ft BNC extension cables from your dealer.

ELECTRICAL WIRING

**Make sure to follow local electrical codes.
SEE TERMINAL BLOCK WIRING ON LAST PAGE.**

Always **interlock the controller with the timer on the main power supply** as shown in Figure 1, to prevent injection of chemicals when the recirculation pump is not running.

The internal transformer is factory set for either **110 VAC** or **230 VAC**. The output of all relays is the same as the input voltage. Make sure to specify the proper input voltage when ordering and to **check the voltage before installation** to avoid serious damage to the control board.

SENSOR INSTALLATION

The sensors can be mounted directly on the main recirculation line (1 ½ or 2 in. diameter) with PVC reducing tees and compression fittings, as shown in Figure 1- or, **preferably, on a bypass line as shown in Figure 4** to protect the sensors from debris, and facilitate sensor cleaning and flow control.

Install the sensors in an **upright position** as shown in Figure 2. Connect each sensor to the proper BNC connector on the controller cabinet. Keep the sensor cables away from high voltage lines, electric motors, power transformers and other electrical equipment.

Tighten the compression fitting by hand only to avoid breaking the internal glass tube in the sensors. Do not use a wrench!

Save the sensor caps for storage or shipping of the sensors. When in storage or shipping, add water in the cap to keep the sensors from drying out. During winter, store the sensors above freezing temperature.

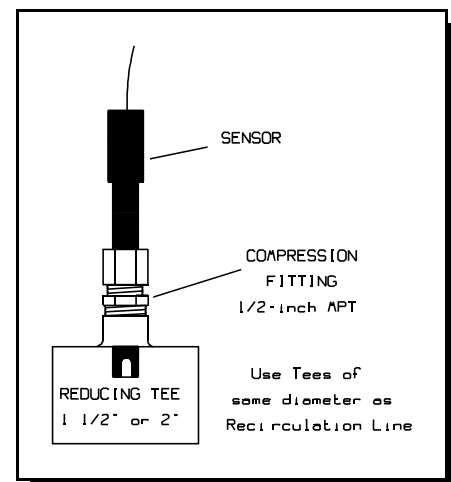

Figure 2 - Sensor Installation

BYPASS LINE

For pipe diameters over 2 in. (50 mm) or whenever **sensor protection from physical damage** is a problem, mount the sensors on a CHEMTROL™ bypass line assembly with a Y-filter, a flowmeter, a rotary safety flow switch, two shutoff valves and a spigot for water testing (Figure 4).

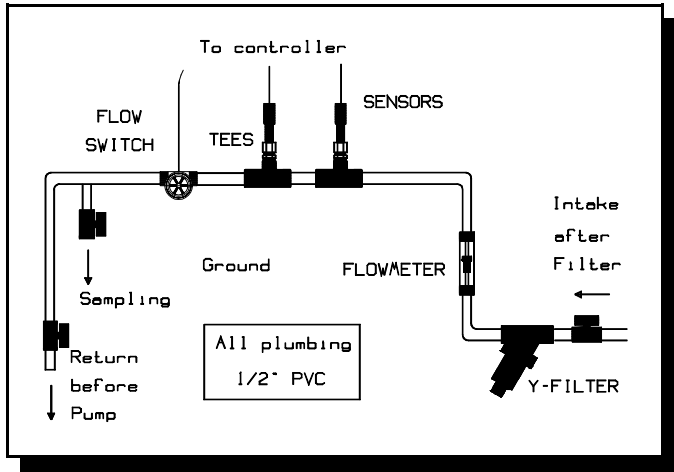

Figure 4 - CHEMTROL™ Bypass Line Assembly

FLOW SWITCH

Note: with a bypass line, a **Safety Flow Switch is absolutely necessary** to prevent accidental feeding of chemicals if the line is shut off or obstructed.

The rotary paddlewheel flow switch connects to the controller terminal block (see schematic on last page) and requires the **jumper on terminal JP19** of the control board (Figure 3) is set to **ON**.

The blade flow switch connects to interrupt the power neutral line (white). Make sure to orient the flow switch in the direction of flow.

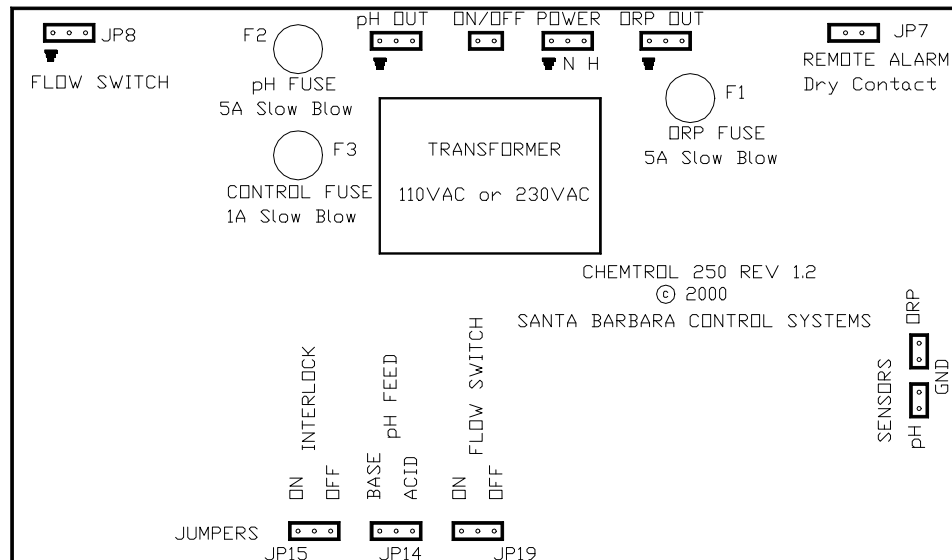

Figure 3 - Control Board

CHEMICAL FEED PUMPS

The feed pumps for liquid chlorine, calcium hypochlorite or dichlor solutions should be installed as shown in Figure 1, according to the manufacturer's instructions. Make sure to **inject all chemicals downstream** of the sensors and equipment to avoid false readings and corrosion.

EROSION FEEDER

With an erosion feeder for bromine or chlorine tablets, install a solenoid valve on the intake side of the bypass line to the erosion feeder as shown in Figure 5

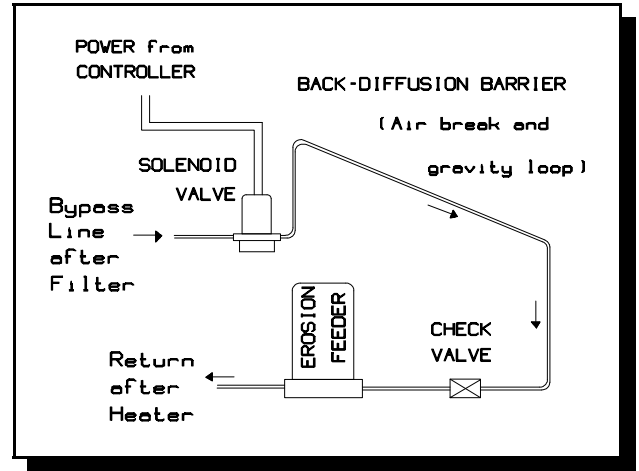

Figure 5 - Erosion Feeder Installation

OPERATION

ACID/BASE JUMPER

The ACID/BASE jumper JP14 on the back of the control board (Figure 3) is factory set for **ACID feed**, i.e. the feed relay is activated when the pH sensor reading is above the setpoint. This is the normal setting for all basic sanitizers, such as liquid chlorine (sodium hypochlorite NaOCl) or dry chlorine (calcium hypochlorite Ca(OCl)₂).

On power up, the controller should display **ACID feed (ACd)**.

However, if you use acidic sanitizers (such as trichlor tablets), the ACID/BASE jumper JP14 should be set to **BASE feed**. This operation should be done only by a qualified operator during installation or when changing the type of sanitizer.

On power up, the controller should then display **BASE feed (bSE)**.

FEED MODE

The feed mode for the sanitizer or pH can be set to OFF, Manual or Automatic. To select the desired feed mode, press **[ORP]** or **[pH]** until the corresponding LED indicator light is illuminated. There is a short delay before activation. (Note: Holding the switch for more than 5 seconds resets the setpoint and calibration for **[ORP]** or **[pH]** to original factory values).

ORP CONTROL SETPOINT

The ORP setpoint is factory set at 700 mV, which is recommended to maintain water quality by killing germs and bacteria. There is no need for ORP calibration.

The chlorine or bromine concentration required to generate a desired ORP value varies with pH and overall water quality, particularly Total Dissolved Solids (TDS) concentration, organic load and cyanuric stabilizer concentration.

The ORP setpoint may have to be adjusted to meet local Health Department requirements in terms of chlorine or bromine level.

To change the ORP control setpoint:

- press **[SETPOINT]**,
- press **[ORP]**: the display flashes,
- use the **[UP]** and **[DOWN]** arrows to adjust the ORP value,
- press **[SETPOINT]** again to save the new value.

pH CALIBRATION

To calibrate the pH, use a reliable, fresh test kit (Phenol Red). Note the value of the pH and compare it to the display value.

To change the pH calibration:

- press **[CALIBRATION]**,
- press **[pH]**: the display flashes,
- use the **[UP]** and **[DOWN]** arrows to adjust the pH value,
- press **[CALIBRATION]** again to save the new value.

pH CONTROL SETPOINT

The pH setpoint is preset at 7.5, which is recommended for pool and spa applications.

To change the pH control setpoint:

- press **[SETPOINT]**,
- press **[pH]**: the display flashes,
- use the **[UP]** and **[DOWN]** arrows to adjust the pH value,
- press **[SETPOINT]** again to save the new value.

OVERFEED SAFETY TIMERS

The internal safety timers are designed to alert the operator in case of overfeeding of chemicals as a result of mechanical or electronic failure or empty containers.

The timers are factory set at 15 minutes for ORP and 5 minutes for pH. This is normally sufficient to reach the setpoint. At that time feeding stops and the timer resets to zero. If the limit is

reached however, the feeder is deactivated, the alarm turned on and the display flashes the overfeed time. The operator should then check the chemical feeders, feed lines and tanks. After correcting the problem, the safety timer is reset by switching the feed mode to OFF and then back to AUTO.

To change the limits of a safety timer:

- press **[SAFETY TIMER]**,
- press **[ORP]** or **[pH]** : the display flashes,
- use the **[UP]** and **[DOWN]** arrows to adjust the value,
- press **[SAFETY TIMER]** again to save the new value.

CAUTION: Increasing the limit on a safety timer may cause overfeeding of chemicals.

OUT-OF-RANGE ALARMS

The out-of-range alarms are factory set at 650 to 900 mV for ORP and 7.0 to 8.0 for pH . If the ORP is below the low limit, the red LED alarm flashes *but sanitizer feed continues*.

If the pH limits are exceeded, the red LED alarm flashes and *all feeders (pH and sanitizer) are deactivated* - unless the sanitizer/pH interlock is defeated (see below).

To change an alarm limit:

- press **[LOW LIMIT]** or **[HIGH LIMIT]**,
- press **[ORP]** or **[pH]**: the display flashes,
- use the **[UP]** and **[DOWN]** arrows to adjust the value,
- press **[LOW LIMIT]** or **[HIGH LIMIT]** again.

CAUTION: Increasing the out-of-range limits may cause overfeeding of chemicals.

SANITIZER/pH INTERLOCK

The Sanitizer/pH Interlock is a safety feature designed to deactivate the sanitizer feed when the pH is out of range. This is particularly important with liquid chlorine, a strong basic chemical that raises the pH of the water.

This feature can be defeated by positioning the Interlock Jumper marked JP15 to the OFF position (Figure 3). This operation should be done only by a qualified operator.

REMOTE ALARM

The remote alarm is connected through the terminal block to the terminal marked JP7 on the control board (Figure 3). It is a dry contact (non powered) used to activate a remote alarm such as a light, a buzzer or a bell.

This alarm contact can also be used to activate an automatic telephone dialer with voice messaging capability.

PROPORTIONAL FEED

There are two ways to control the feed rate.

In standard ON/OFF control (Figure 5), the feed rate remains constant until the setpoint is reached, whereupon it stops.

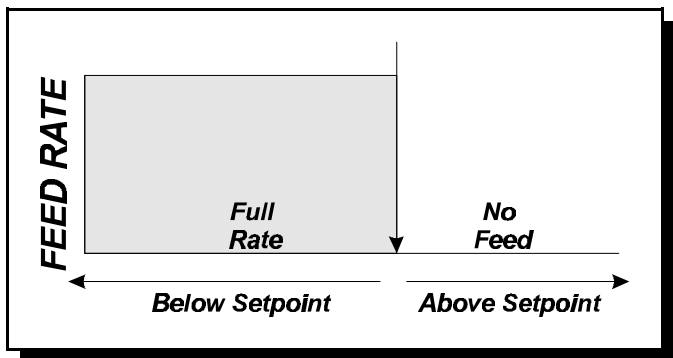

Figure 6 - Standard ON/OFF Feed Control

In proportional control (Figure 7), the feed rate decreases progressively as it approaches the setpoint. Proportional control is particularly useful to avoid overfeeding of chemicals in small bodies of water.

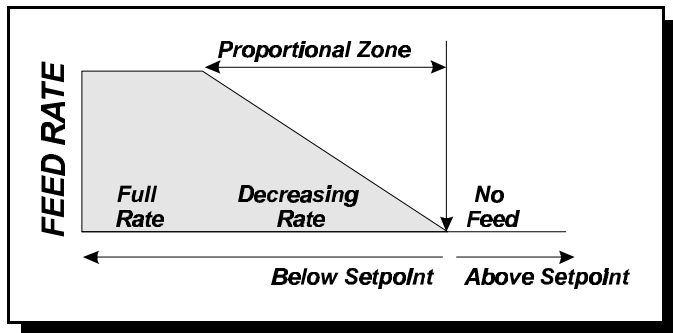

Figure 7 - Proportional Feed Control

In the Proportional Zone, activation of the chemical feeder is based on 1-minute cycles with varying ratios of ON and OFF feed times. As the sensor reading approaches the setpoint value, the ON portion of the cycle decreases progressively. During the OFF portion, the feed light flashes continuously to indicate that the controller is under proportional control.

The default value for the width of the proportional zone is factory set at its lowest value, 1% of the setpoint, which corresponds to the deadband for ON/OFF control. The feed rate can be decreased by *increasing* the width of the zone or increased by *reducing* the width of the zone.

To change the width of the Proportional Zone:

- press **[PROPORTIONAL CONTROL]**,
- press **[ORP]** or **[pH]**: the display flashes,
- use the **[UP]** and **[DOWN]** arrows to adjust the value,
- press **[PROPORTIONAL CONTROL]** again to save the new value.

CONTROLLER RESET

The CHEMTROL™ 250 controller is unique in that it saves both user-defined values as well as factory defaults in its internal non-volatile memory. Therefore, user-modified setpoints and acid/base feed modes will not be lost in the event of power failure and factory default values can be restored at any time.

To reset the setpoint and calibration values to the original factory values, press and hold **[ORP]** or **[pH]** for 5 seconds.

To reset all functions to the original factory values, press and hold **both [ORP] and [pH]** for 5 seconds.

STARTUP

DEFAULT PARAMETERS

	[ORP]	[pH]
Setpoint	700 mV	7.5
High/Low Alarms	650 / 900 mV	7.0 / 8.0
Overfeed Safety Alarm	15 min.	5 min.
Proportional Bandwidth	1%	1%

WATER CHEMISTRY

Before starting automatic control, test the water chemistry to make sure that the pH, Cyanuric Acid and Total Dissolved Solids are within the ranges recommended by the National Spa and Pool Institute (NSPI).

The **pH should be adjusted manually within 7.4 to 7.6**. If it is below 7.0 or above 8.0, the controller will show an alarm condition and prevent feeding.

To stabilize chlorine against solar UV radiation, a **cyanuric acid level of 20 to 25 ppm** is ideal. However, this level can be quickly exceeded with stabilized chlorine (dichlor or trichlor). Note that many Health Department codes do not allow stabilizer levels above 100 ppm. If above 100 ppm, this results in "chlorine lock" which shows as low ORP readings even with high chlorine levels.

The **Total Dissolved Solid (TDS) level should be below 2,000 ppm**. If higher, the water is full of organic and inorganic impurities and should be replaced partially or completely.

For effective pH control, the **Total Alkalinity should be between 80 to 120 ppm**. If too low, the pH will bounce and be hard to control. If too high, the pH will be hard to change.

AUTOMATIC CONTROL

1. Run the recirculation pump with both sensors in line at least 30 minutes to stabilize the sensor readings.
2. Turn the controller on. The displays will show
 - a. the software version number,
 - b. **[ACd]** for Acid feed or **[bSE]** for Base feed,
 - c. **[IL]** if the sanitizer/pH interlock is on.
 - d. the sensor readings.
3. Press **[ORP]** until the feed control light is on AUTO.
4. Press **[pH]** until the feed control light is on AUTO.
5. After 30 minutes, test the pH of the water with a Phenol Red test kit. Adjust the pH calibration if needed.

6. Test the free chlorine or bromine ppm in the water with a DPD test kit. Adjust the ORP setpoint if required.
7. Test the water regularly as required by local health authorities.

MAINTENANCE

The **CHEMTROL™ 250** controller is virtually maintenance free. The enclosure and front panel can be cleaned with a soft cloth moistened with a mild soap and water solution or a glass cleaner. Do not use abrasives or harsh chemicals.

GENERAL MAINTENANCE

For commercial and public pools, it is important to test and record the water chemistry readings in compliance with Health Department requirements using a good quality manual test kit. Adjust the pH calibration or ORP setpoint as required.

It is important to note that changes in pH, cyanuric acid concentration, total dissolved solids, and use of additional or alternative sanitizers will all impact the primary sanitizer residual level in comparison to ORP. To maintain a consistent sanitizer residual in parts-per-million (ppm), adjust the ORP setpoint as required.

SENSOR TESTING

To test the sensors on line, carefully add a small amount of white vinegar or dilute acid solution in the skimmer. After a few minutes:

- the pH reading should go DOWN.
- the ORP reading should go UP.

If you still get no response or a sluggish response, clean or replace the sensors as soon as possible.

SENSOR CLEANING

The sensor tips must be kept clean and free from chemical deposits and contamination to function properly. After saturation in pool or spa water, the sensors may need to be cleaned on a weekly or monthly basis depending on the water quality and other facility-specific characteristics. Slow response and inconsistent readings are indications that the sensors are in need of cleaning.

To clean a sensor, carefully remove it from the compression fitting. Clean the tip of the sensor with a mild liquid detergent (Joy, etc.) solution. Rinse with fresh water and soak the sensor in a mild acid solution for five minutes. Rinse with fresh water and reinstall the sensor.

SENSOR REPLACEMENT

For optimum controller performance, always use genuine CHEMTROL™ replacement sensors. For preventive maintenance it is also recommended to replace the sensors on an annual basis or as performance diminishes.

SENSOR STORAGE

Extended exposure to atmospheric conditions will cause the

sensor tips to dry out. Always remove and properly store the sensors if the pool or spa is to be winterized or inactive. Store the sensors with the original cap provided, making sure that each cap is filled with the original storage solution or clean water. If the storage containers have been misplaced, store the sensors individually in small glass or plastic containers with clean water covering the sensor tips.

WINTERIZATION

The sensors should be prepared for storage as outlined above and protected from freezing. Although the **CHEMTROL™ 250** controller is designed to withstand a broad temperature range, winter storage in a secure location at normal room temperature is recommended.

PARTS LIST

PCB250/115	Control board for CH250, 115V.
PCB250/230	Control board for CH250, 230V.
ORP	ORP sensor with 10-ft BNC cable.
pH	pH sensor with 10-ft BNC cable.
PKT-2.0	Set of two (2) PVC tees and compression fittings for 2 in. (50 mm) line.
PKT-1.5	Set of two (2) PVC tees and compression fittings for 1.5 in. (37 mm) line.

OPTIONS

BPL-0.5	½" Bypass line assembly with Y-filter, flowmeter, safety flow switch, two (2) shutoff valves and sampling tap.
PWFS	Rotary paddle-wheel safety flow switch.
FCA	Machined transparent polycarbonate flow cell assembly for sensors.
XC25	Sensor cable extension with BNC connectors, 25-ft (8 m).
XC50	Sensor cable extension with BNC connectors, 50-ft (16 m).
DIAL	Telephone dialer with voice messaging.

SPECIFICATIONS

Cabinet	Polystyrene (9.5x7.25" or 23.5x18 cm)
ORP Display	0 to 999 mV
pH Display	0 to 14
ORP Setpoint	250 to 950 mV
pH Setpoint	4.5 to 9.5
ORP Accuracy	+/- 5.0 MV
pH Accuracy	+/- 0.1 pH
ORP Control	Off / Manual / Automatic / Proportional
pH Control	Off / Manual / Automatic / Proportional
pH Feed	Acid or Base Feed.
ORP Functions	Auto / Setpoint
pH Functions	Auto / Set point/ Calibration
Safety Systems	Visual and Remote Alarms
Control	Comprehensive Diagnostic Self-Test
ORP Output	5 Amp/120 or 230 VAC
pH Output	5 Amp/120 or 230 VAC
Remote Alarm	Dry contact for audio, visual or telephone dialer.

TROUBLESHOOTING

- No lights on.**
 1. Check the circuit breaker and/or receptacle for proper operation. Connect to functional grounding-type GFCI protected power source.
 2. Check for a damaged power connector.
 3. Check internal fuse (1A slow blow) marked F3 on control board.

- Alarm lights and buzzer on.**
 1. Verify that the filtration system is functioning properly, water flow is adequate and water chemistry is in balance.
 2. Verify that sensor and power cables are properly connected to the respective connectors on the controller.
 3. Check the operation of the chemical feeders (pumps or erosion feeder).
 4. Verify that the (optional) flow sensor is properly installed.

- Illogical pH and ORP value displays.**
 1. The sensor cable connections may be reversed. Verify that the sensor cables are properly connected to their respective BNC connectors on the controller unit.
 2. Verify that the filtration system is functioning properly, the water flow is adequate, and the water chemistry is in balance.

- ORP feeder does not activate.**
 1. Make sure the AUTO feed light for ORP is on.
 2. Check the ORP setpoint.
 3. Check ORP relay fuse (5A slow blow) marked F1 on control board.
 4. Check safety flow switch on bypass line and jumper JP19 on control board.

- pH feeder does not activate.**
 1. Verify that the acid/base feed jumper JP14 on the control board is properly set.
 2. Make sure the AUTO feed light for pH is on.
 3. Check the pH setpoint.
 4. Check pH relay fuse (5A slow blow) marked F2 on control board.
 5. Check safety flow switch on bypass line.

- Chlorine or bromine residual too high or too low.**
 1. Remember that the pH, cyanuric acid concentration, total dissolved solids, and use of additional or alternative sanitizers will all impact the sanitizer residual level in comparison to ORP. Consider the impact of any chemicals recently added to the pool or spa.
 2. Check and adjust the ORP setpoint.

- pH requires frequent calibration.**
 1. Clean or replace the sensor as outlined in the maintenance section.

- Inconsistent or slow pH or ORP readings.**
 1. Verify that the sensor cables are properly connected to their respective BNC connectors on the controller unit.
 2. Clean the sensors as outlined in the maintenance section.
 3. Check to verify that all electrical equipment in the facility pump room is properly grounded.
 4. Replace the sensors if needed.

- Chemical feeder runs continuously.**
 1. Make sure the AUTO feed mode is selected.
 2. Verify that the chemical feeders are properly connected to their respective connectors on the controller unit.

- pH or ORP overshoots setpoint.**
 1. Increase the width of the proportional zone.
 2. Check the dilution of sanitizer or acid/base solution.

- pH or ORP does not reach setpoint.**
 1. Decrease the width of the proportional zone.
 2. Increase the concentration of sanitizer or acid/base solution.
 3. Check chemical feeders for proper operation.

TERMINAL BLOCK WIRING

B	W	G				B	W	G			B	W	G	
ORP Feeder			R	W	B	Power Input			Dry Contact Alarm			pH Feeder		
			Rotary Flowswitch											

B= Black W=White G=Green R=Red
WARNING: Rotary Flowswitch is 5VDC. Do not wire to high voltage!